

BMC-R Series

CNC Boring & Milling Machines



Manufacturing high quality machine tools since 1958



FEMCO's First Boring Mill

FEMCO has been manufacturing quality machine tools for over five decades. We pride ourselves in quality and our research & development department is constantly looking for ways to improve our products. In 1978, FEMCO became one of the first Taiwanese machine tool builders to manufacture boring mills. Today FEMCO boring mills are considered the world leader in quality and value.

1978 FEMCO Model WBT-85 Boring Mill



Standard Machine Features

- Meehanite Castings for all major parts
- Simultaneous 4 axis control for X, Y, Z and W-axis
- Standard feed rates on all axes, 0.2-157.48" min.
- Can be equipped with 60/90 Station ATC
- Can be equipped with optional through spindle coolant system
- Linear scales on X, Y, Z-axes form a closed loop feedback control system
- Powerful hydraulic system clamps rotary table
- Universal CNC indexing table (B-axis)
- FANUC 21iMB CNC is standard

High Performance Spindle

For highest rigidity performance with minimal wear, spindle and sleeve surfaces are made of Aluminum Chromium Molybdenum steel and hardened with a nitride process.



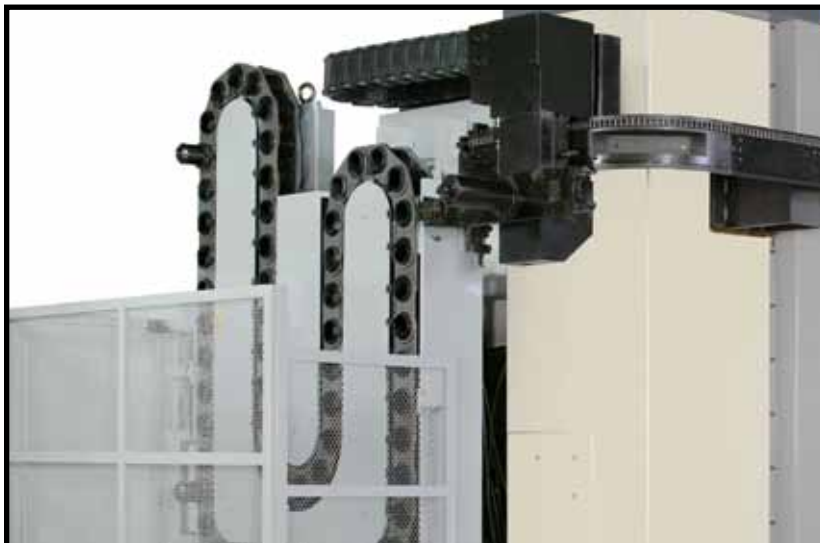

Automatic Tool Changer

The optional ATC holds 60 or 90 tools with a twin tool arm that keeps the next tool at ready position. The easy access open-face design ensures fast loading and unloading. CT-50 tool holders allow for a wide range of tooling options.



CNC Controller

The machine is standard equipped with a FANUC 21iMB controller.



Versatile Rotary Table

The rotary table features 6 hydraulically powered clamping pads that perform at 315-320 kg/cm² and a hydraulically actuated shot pin for every 90° position. For true automation, the optional full 4th B-Axis allows for 360.000 positioning. To save set-up time, waiting time and machining hours, the machine allows machining of all sides at the same level in one set-up. Machining processes can include boring, drilling, and tapping. To minimize wear and negative friction, all Box Ways are lined with Turcite-B. The table's surrounding chip/coolant pan collects and directs coolant and metal waste to the chip conveyor and receptacle.

Model	Height	Length	Width	Model	Height	Length	Width
BMC-110R1	132.67"	220.35"	207.28"	BMC-110R3	146.46"	257.13"	250.31"
BMC-110R2	146.46"	257.13"	215.91"	BMC-135R	190.55"	286.34"	245.63"

BMC- 110R1

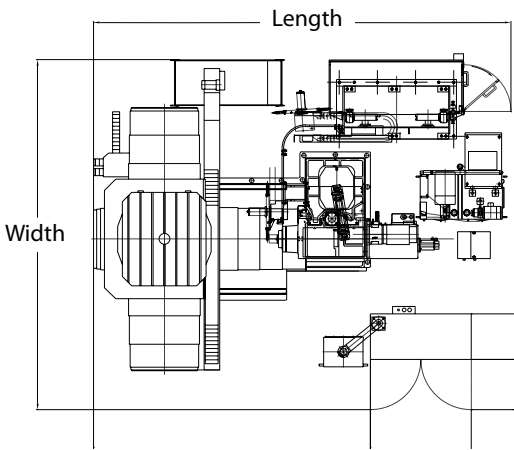
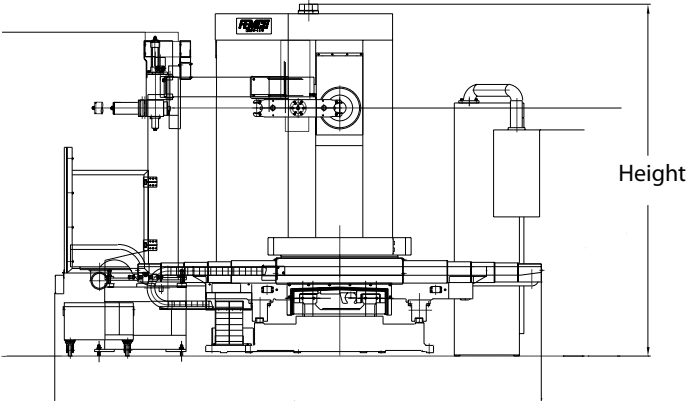

BMC-110R2, BMC-110R3

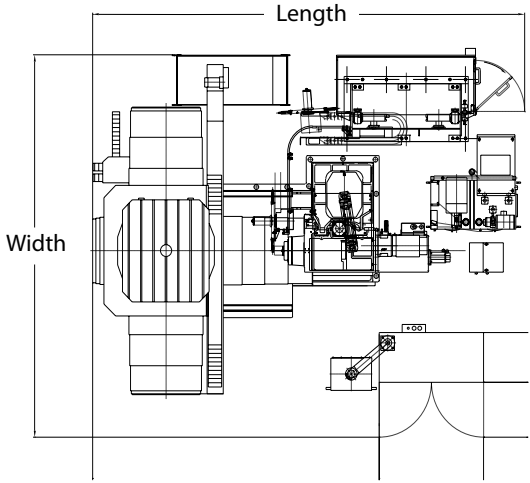
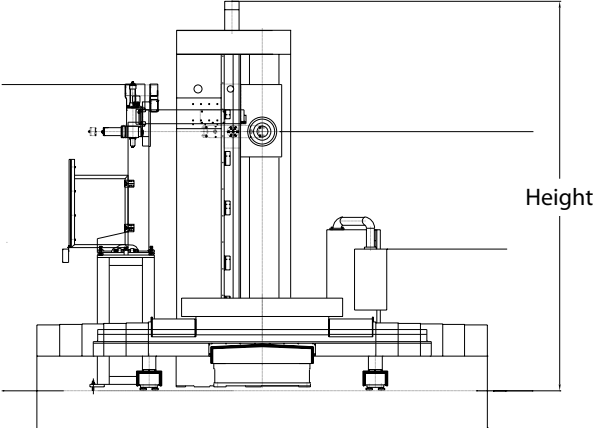

BMC-135R

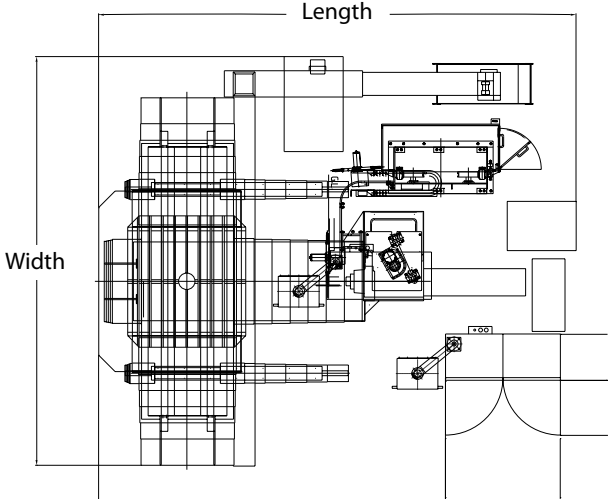
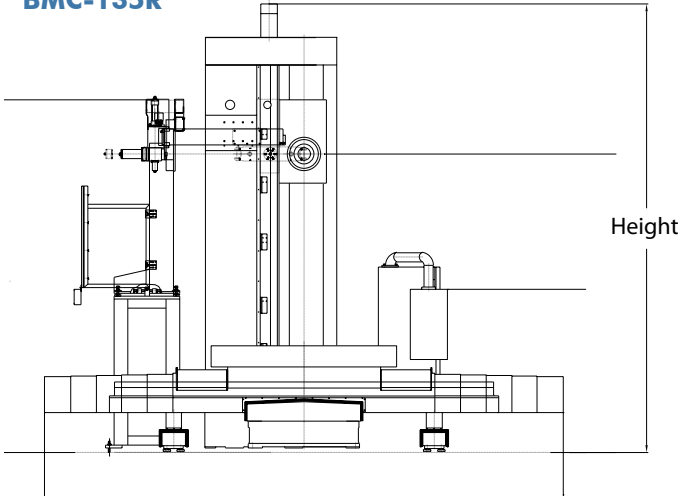



Specifications

BMC-110R1

BMC-110R2

BMC-110R3

BMC-135

Travel

Table Cross Travel (X)	55.12" (1400mm)	78.74" (2000mm)	118.11" (3000mm)	94.49"(2400mm)
Headstock Travel (Y)	47.24" (1200mm)	70.87" (1800mm)	70.87"(1800mm)	82.68"(2100mm)
Table Longitudinal (Z)	43.31" (1100mm)	66.93" (1700mm)	66.93"(1700mm)	59.06"(1500mm)

Table

Size	44.09" x 49.21"	56.69" x 62.99"	56.69" x 62.99"	70.87" x 78.74"
Load	8,819 lbs (4000kg)	13889 lbs (6300kg)	13,889lbs (6300kg)	22046lbs. (10000kg)

Spindle

Stroke (W)	19.69" (500mm)	19.69" (500mm)	19.69" (500mm)	35.43" (900mm)
Diameter	4.33" (110mm)	4.33" (110mm)	4.33" (110mm)	5.31"(135mm)
Taper (w/power operated drawbar)	ISO #50	ISO #50	ISO #50	ISO #50
Toolshank	CT50	CT50	CT50	CT50
Pull Stud (MASI option)	MASII 60 deg	MASII 60 deg	MASII 60 deg	MASII 60 deg
Milling Spindle Diameter	8.86" (225mm)	8.86" (225mm)	8.86" (225mm)	8.86" (225mm)
Motor	30/35 H.P. (AC 22/26KW)	30/35hp (AC 22/26KW)	30/35hp (AC 22/26KW)	30/35hp (AC 22/26KW)
Low Speed Range	Stepless 5-454 RPM	Stepless 5-454 RPM	Stepless 5-454 RPM 10 -	Stepless 10-350 RPM
High Speed Range	Stepless 455 to 2,500 RPM	Stepless 455 to 2,500RPM	Stepless 455 to 2,500RPM	Stepless 350-1500 RPM

Automatic Tool Changer

Tool Storage Capacity	60, 90 tools	60, 90 tools	60, 90 tools	60, 90 tools
Maximum Tool Weight	55lbs (25kg)	55lbs (25kg)	55lbs (25kg)	55lbs (25kg)
Maximum Tool Diameter (Adjacent Pods Full)	4.72" (120mm)	4.72" (120mm)	4.72" (120mm)	4.72" (120mm)
Maximum Tool Diameter (Adjacent Pods Empty)	9.84" (250mm)	9.84" (250mm)	9.84" (250mm)	9.84" (250mm)
Maximum Tool Length	15.75" (400mm)	15.75" (400mm)	15.75" (400mm)	15.75" (400mm)
Tool to Tool Exchange Time	15 sec	15 sec	15 sec	15 sec
Tool Selection Method	automatic selection	automatic selection	automatic selection	automatic selection

Positioning Servo Motor

X-Axis	8.0 hp (AC 5.97KW)	8.0hp (AC 5.97KW)	8.0hp (AC 5.97KW)	12.1hp (AC 7.3KW)
Y-Axis	9.4 hp (AC 7.0KW)	9.4hp (AC 7.0KW)	9.4hp (AC 7.0KW)	12.1hp (AC 7.3KW)
Z-Axis	8.0 hp (AC 5.97KW)	8.0hp (AC 5.97KW)	8.0hp (AC 5.97KW)	12.1hp (AC 7.3KW)
W-Axis	5.4 hp (AC 4.0KW)	5.4hp (AC 4.0KW)	5.4hp (AC 4.0KW)	9.4 hp (AC 7.0KW)
B-Axis	5.1 hp (AC 3.8KW)	5.1hp (AC 3.8KW)	5.1hp (AC 3.8KW)	4.4 hp (AC 3.3KW)

Control

Positioning Accuracy X,Y, Z, and W-Axis	0.001"/11.81"	0.001"/11.81"	0.001"/11.81"	0.001"/11.81"
Repeatability X,Y,Z, and W-Axis	± 0.0004"(± 0.01mm)	± 0.0004"(± 0.01mm)	± 0.0004"(± 0.01mm)	± 0.0004"(± 0.01mm)
Control Axis	5	5	5	5
Simultaneous Control Axis	4	4	4	4

Rapid Traverse Rate

X,Y,Z Axis	394"min(10m/min)	394"min(10m/min)	394"min(10m/min)	378"min(9.6m/min)
W-Axis	157"min(6m/min)	157"min(4m/min)	157"min(4m/min)	157"min(4m/min)

Machine Weight/Dimensions

L x W	220.35" x 207.28"	257.13" x 215.91"	257.13" x 250.31"	286.34" x 245.63"
Machine Height	132.67" (3370mm)	146.6" (3720mm)	146.46"(3720mm)	190.55" (4840mm)
Weight	35,274lbs.	41,887lbs.	46,297lbs.	57,320lbs.

Power Requirements

220v. 3Ph. 60 cycle 100amp. 440v. Transformer on request	220v. 3Ph. 60 cycle 100amp. 440v. Transformer on request	220v. 3Ph. 60 cycle 100amp. 440v. Transformer on request	220v. 3Ph. 60 cycle 100amp. 440v. Transformer on request
---	---	---	---



U.S. Headquarters

FEMCO

7142 Belgrave Ave.
Garden Grove, CA 92841
Tel:(714)898-2066 Fax:(714)891-2813
info@femcousa.com

U.S. Branch

FEMCO of Texas

5829 W. Sam Houston Pkwy. N.
Suite #805
Houston, TX 77041
Tel:(713)937-7771 Fax:(713)937-1239
texas@femcousa.com

Service & Parts

Our large Service and Parts staff provide outstanding support to its distributors and customers.

FEMCO Service Engineers come equipped to get your machine up and running as soon as possible. FEMCO USA has a large well stocked parts department.

Applications

Our highly qualified Applications experts offer the following services:

- Personnel Instruction
- Training Services
- Applications Consulting
- Turnkey and Part Processing Services



Visit our web site to locate a dealer near you. www.femcousa.com